



AURELIA II

nuova
SIMONELLI



 **nuova**
SIMONELLI[®]
espresso coffee machines

Destino vincente

IT Come ogni campione sa, vincere è difficile, confermarsi vincitore ancora di più. È questa la grande sfida che era stata assegnata ad Aurelia II e che essa ha dimostrato di saper superare.

Aurelia II si è confermata ancora una volta la macchina ufficiale del WBC. Un traguardo di prestigio, indice di una qualità superiore. Oltre a riproporre tutti i pregi (SIS, Ergonomia, ...) della sua antenata, Aurelia II presenta tante interessanti novità che la proiettano verso nuovi e sempre più ambiziosi orizzonti.

Ora Aurelia II è pronta a mettere a disposizione tutto il suo valore ad ogni barista che avrà il piacere di utilizzarla.



2009 – WBC Atlanta



2010 – WBC London



2011 – WBC Bogotà



Destined to win

EN As every champion knows, winning is difficult, to be confirmed the winner even more so. This is the great challenge that was given to Aurelia II and that it showed it could overcome.

Aurelia II was confirmed once again as the official coffee machine of the WBC. A prestigious goal, an indication of superior quality. In addition to having all the advantages of its predecessor (SIS, ergonomics, ...), Aurelia II has many interesting new features that point towards new and more ambitious horizons.

Now Aurelia II is ready to make all of its value available to every barista who will be happy to use it.

Le destin gagnant

FR Comme tous les champions le savent, s'il est difficile de gagner, il l'est encore plus de s'affirmer en tant que vainqueur. C'est le grand défi qui a été attribué à Aurelia II et que cette dernière a gagné avec succès.

Aurelia II s'est confirmée encore une fois comme la machine officielle du WBC. Un objectif de prestige, indice d'une qualité supérieure. Aurelia II propose toutes les qualités (SIS, ergonomie, etc.) de son antécédente, mais contient également des nouveautés intéressantes qui le projettent vers des horizons nouveaux et toujours plus ambitieux.

A présent, Aurelia II est prête pour mettre toute sa valeur à disposition des barmans qui auront le plaisir de l'utiliser.

Zum Siegen bestimmt

DE Wie jeder Champion weiß, ist siegen schwierig, sich als Sieger zu bestätigen, noch schwieriger. Das ist die große Herausforderung, vor die Aurelia II gestellt wurde, und die sie zu bewältigen verstanden hat.

Aurelia II ist auch diesmal wieder die offizielle Kaffeemaschine der WBC. Ein anspruchsvolles Ziel, das ein Zeichen für höchste Qualität ist. Zusätzlich zu all den Vorteilen (SIS, Ergonomie, ...) ihrer Vorgängerin, bietet Aurelia II viele interessante Neuheiten, die sie neuen und immer ehrgeizigen Horizonten entgegenführen.

Aurelia II steht nun bereit, um ihre großen Vorzüge jedem Barista zur Verfügung zu stellen, der die Freude haben wird, sie zu benutzen.

Destino ganador

ES Como saben todos los campeones, ganar es difícil, consolidarse como ganador todavía más. Es este el gran reto que se había asignado a Aurelia II y que ella ha demostrado saber superar.

Aurelia II se ha confirmado una vez más la máquina oficial del WBC. Una meta prestigiosa, índice de una calidad superior. Además de volver a proponer todos los valores (SIS, Ergonomía...) de su predecesora, Aurelia II presenta tantas interesantes novedades que la proyectan hacia nuevos y cada vez más ambiciosos horizontes.

Ahora Aurelia II está lista para poner a disposición de cada barista que tenga el placer de usarla todo su valor.



**La migliore Aurelia di sempre
The best Aurelia of all times**

Forza e carattere

IT Aurelia II trasmette forza e ricchezza fin dal primo sguardo. La Forza di una tecnologia all'avanguardia e la ricchezza di un valore riscontrabile non appena la si esamina più in dettaglio. A dominare è la lucentezza dell'acciaio che unita al dinamismo delle forme, dona ad Aurelia II un appeal invidiabile.

Carattere, Solidità, Ricchezza, Forza e Affidabilità. Sono questi i tratti distintivi di Aurelia II, garantiti dalla sofisticata tecnologia Nuova Simonelli e richiamati da un design inconfondibile.



Strength and character

EN Aurelia II exudes strength and richness at first glance. The Strength of breakthrough technology and a richness of value to be found as soon as we examine it in a more detailed way. The brilliance of stainless steel is outstanding, combining the dynamism of forms, giving Aurelia II enviable appeal.

Character, Solidity, Richness, Strength and Reliability. These are the hallmarks of Aurelia II, backed by sophisticated Nuova Simonelli technology and enhanced by a unique design.

Force et caractère

FR Aurelia II transmet sa force et sa richesse dès le premier regard. La force d'une technologie à l'avant-garde et la richesse d'une valeur appréciable dès qu'on l'examine de plus près dans tous ses détails. Ce qui domine avant tout est la brillance de l'acier qui, mêlée au dynamisme des formes, confère à Aurelia II un attrait enviable.

Caractère, Solidité, Richesse, Force et Fiabilité. Ce sont les signes de distinction de Aurelia II, garantis par la technologie sophistiquée de Nuova Simonelli et au design inimitable.

Kraft und Charakter

DE Aurelia II vermittelt auf den ersten Blick Kraft und Reichtum. Die Kraft einer hoch fortschrittlichen Technologie und den Reichtum eines Werts, der ins Auge fällt, sobald man sie näher untersucht. Dominant ist das Glitzern des Stahls, das Aurelia II in Verbindung mit den dynamischen Formen einen beneidenswerten Appeal verleiht.

Charakter, Solidität, Reichtum, Kraft und Zuverlässigkeit. Die sind die Charakterzüge von Aurelia II, die durch die ausgefeilte Technologie von Nuova Simonelli bestimmt und durch das unverwechselbare Design verstärkt werden.

Fuerza y carácter

ES Aurelia II transmite fuerza y riqueza desde la primera mirada. La Fuerza de una tecnología vanguardista y la riqueza de un valor que se descubre en cuanto se examina más detalladamente. Domina el brillo del acero que unido al dinamismo de las formas, da a Aurelia II un atractivo envidiable.

Carácter, Solidez, Riqueza, Fuerza y Fiabilidad. Son éstos los rasgos que distinguen a Aurelia II, garantizados por la sofisticada tecnología Nuova Simonelli y justificados por un diseño inconfundible.



Prestazioni
e consistenza



**Performance
and consistency**

**Performances
et consistance**

**Leistung
und Konstanz**

**Prestación
y consistencia**



SIS
Soft Infusion
System

IT Aurelia II ripropone il già collaudato sistema SIS che è sinonimo di estrazioni cremose e di qualità superiore.

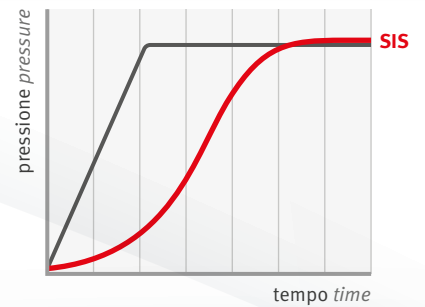

EN Aurelia II presents again the tested SIS system that is synonymous with superior quality and creamy extractions.

FR Aurelia II repropose le système SIS déjà largement testé, synonyme d'extractions crémeuses et de qualité supérieure.

DE Aurelia II bietet auch das bewährte System SIS, welches für cremigen Espresso von höchster Qualität steht.

ES Aurelia II vuelve a proponer el ya probado sistema SIS que es sinónimo de extracciones cremosas y de calidad superior.



PID
Proportional
Integral
Derivative

IT L'innovativo pressotato digitale è uno strumento molto accurato nel determinare con precisione la temperatura dell'acqua in caldaia. Il barista può controllarla e programmarla direttamente dal display.

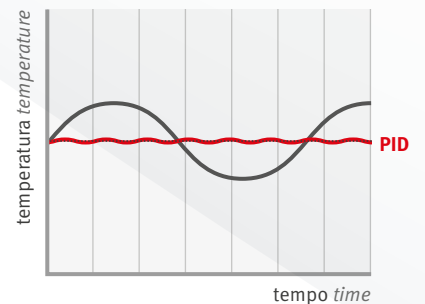

EN This innovative digital pressure switch is a very accurate tool determining the precise temperature of water in the boiler. The barista can control and program it directly from the display.

FR Le nouveau pressostat digital est un instrument très précis pour déterminer la température de l'eau dans la chaudière. Le barman peut la contrôler et la programmer directement depuis l'afficheur.

DE Dieser innovative digitale Druckschalter ist ein sehr genaues Instrument zur exakten Feststellung der Wassertemperatur im Boiler. Der Barista kann sie direkt am Display kontrollieren und programmieren.

ES El innovador presostato digital es un instrumento muy preciso para determinar con exactitud la temperatura del agua en la caldera. El barista puede controlarla y programarla directamente desde la pantalla.

Versatilità e funzionalità



Raised groups

IT La macchina può essere richiesta con i gruppi ad altezza regolare (80 mm) o ad altezza maggiorata (125 mm) se si vuole operare anche con bicchieri alti.



Autosteam

IT Con Aurelia II non serve più esperienza e formazione per preparare cremosi e vellutati cappuccini. Con il sistema Autosteam tutti i cappuccini avranno la stessa fragranza e la stessa temperatura.



Automatic cleaning

IT Aurelia II permette di fare la pulizia automatica indipendente su ogni singolo gruppo. Il lavaggio diventa così sinergico con gli orari di esercizio e non serve più attendere la chiusura.

Versatility
and functionality

Versabilité
et fonctionnalité

Vielseitigkeit
und Funktionalität

Versatilitad
y funcionalidad



EN The machine can be ordered with regular height groups (80 mm) or raised height groups (125 mm) if you also want to work with tall glasses.

FR La machine peut être commandée avec les groupes à hauteur normale (80 mm) ou à une hauteur supérieure (125 mm) si on désire travailler aussi avec des verres hauts.

DE Die Maschine kann auf Anfrage mit Brühgruppen auf normaler Höhe (80 mm) oder mit nach oben verlagerten Brühgruppen (125 mm) geliefert werden, wenn z.B. hohe Gläser verwendet werden sollen.

ES La máquina se puede solicitar con los grupos a una altura regular (80 mm) o a una altura aumentada (125 mm) si se desea trabajar también con los vasos altos.

EN With Aurelia II experience and training is no longer needed to prepare creamy and velvety cappuccinos. With the Autosteam all cappuccinos have the same fragrance and the same temperature.

FR Avec Aurelia II l'expérience et la formation ne sont plus nécessaires pour pouvoir préparer des cappuccinos crémeux et veloutés. Grâce au système Autosteam, tous vos cappuccinos auront la même fragrance et la même température.

DE Mit Aurelia II ist keine Erfahrung oder Ausbildung mehr notwendig, um cremige, samtige Cappuccinos zuzubereiten. Mit dem System Autosteam jeder Cappuccino den gleichen Duft und die gleiche Temperatur.

ES Con Aurelia II ya no sirve la experiencia y formación para preparar cremosas y suaves capuchinos. Con el sistema Autosteam todos los capuchinos tendrán la misma fragancia y la misma temperatura.

EN Aurelia II allows independent automatic cleaning of each individual group. Washing and operating hours can be carried out simultaneously. No need to wait for closing time.

FR Aurelia II permet d'effectuer un nettoyage automatique indépendant de chaque groupe. Le lavage devient ainsi synergique avec les horaires de service et il ne faut plus attendre la fermeture de l'établissement.

DE Aurelia II gestattet die automatische und unabhängige Reinigung der einzelnen Brühgruppen. Das Ausspülen erfolgt also in Synergie mit den Betriebszeiten und es muss nicht mehr gewartet werden, bis das Lokal geschlossen wird.

ES Aurelia II permite hacer la limpieza automática independiente en cada uno de los grupos. El lavado entra en sinergia con los horarios de funcionamiento y ya no hace falta esperar al cierre.

Confort e benessere

IT Aurelia II conferma l'attenzione della Nuova Simonelli per la tutela ed il benessere del barista.

Dal punto di vista ergonomico, oltre a riproporre tutte le soluzioni che hanno reso la sua antenata la prima macchina al mondo ergonomicamente certificata (Leve Push&Pull, Portafiltri inclinati, Ampia visuale piano lavoro ...), Aurelia II presenta nuovi interessanti accorgimenti.



Leather
filter holder

Comfort and well-being

EN Aurelia II confirms Nuova Simonelli's interest in the protection and well-being of the barista.

From the ergonomic point of view, in addition to reproducing all the solutions that made its predecessor the world's first ergonomically certified coffee machine (Push&Pull levers, slanting filter holders, high visibility work surface...) Aurelia II presents interesting new devices.

Confort et bien-être

FR Aurelia II confirme l'attention de Nuova Simonelli pour la sécurité et le bien-être du barman.

Du point de vue ergonomique, outre toutes les solutions qui ont permis à son ancêtre d'être la première machine au monde ergonomiquement certifiée (leviers Push&Pull, Porte-filtres inclinés, Vaste vue sur le plan de travail...), Aurelia II présente de nouveaux détails importants.

Komfort und Wohlbefinden

DE Aurelia II bestätigt das Interesse von Nuova Simonelli für die Sicherheit und das Wohlbefinden des Barista.

Unter ergonomischen Gesichtspunkten bietet Aurelia II außer den Lösungen, die aus dem Vorgänger die erste Maschine der Welt mit Ergonomie-Zertifikat (Push&Pull-Hebel, schräge Siebhalter, gute Übersicht über die Arbeitsfläche...) gemacht haben, neue und interessante Eigenschaften.

Confort y bienestar

ES Aurelia II confirma la atención de la Nuova Simonelli por la tutela y el bienestar del barista.

Desde el punto de vista ergonómico, además de volver a proponer todas las soluciones que han hecho su antecesor la primera máquina en el mundo ergonómicamente certificada (Palancas Push&Pull, portafiltros inclinados, Amplia visual plano de trabajo...) Aurelia II presenta nuevos interesantes detalles.

- 1 Push&pull 2 Wide view 3 Conical handel 4 Inclined handle 5 Reverse mirror

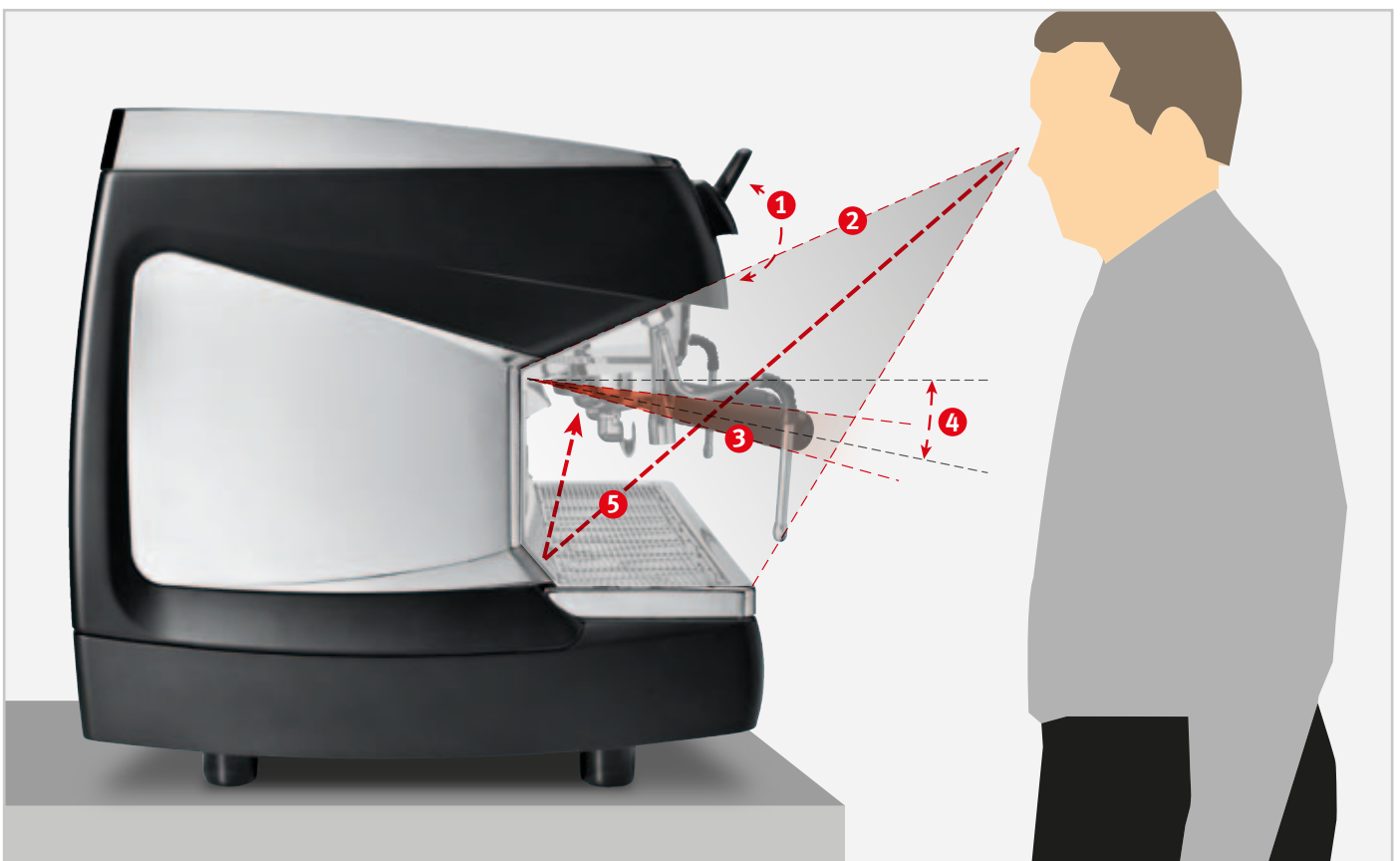

Ergonomia e sicurezza



Reverse mirror

IT Consente al barista di osservare l'uscita del caffè dal portafiltro senza doversi chinare. Una piccola accortezza che sarà molto apprezzata dai baristi professionisti.



Milk light

IT Porta luce all'interno del bricco latte, ovvero in uno degli angoli più bui per il barista, permettendogli di visualizzare ottimamente la fase di montaggio.



LED light

IT Nuovo anche il sistema di illuminazione del piano lavoro che garantisce uniforme intensità di luce su tutta la superficie.



Cool touch

IT Le lance vapore hanno il sistema brevettato *cool touch*, che, oltre a garantire maggiore sicurezza contro fastidiose ustioni, assicura una più facile pulizia; stop alle incrostazioni di latte.

Ergonomics and security

Ergonomie et sécurité

Ergonomie und Sicherheit

Ergonomia y seguridad

EN It allows the barista to watch the coffee filter output without bending down. A little foresight that will be appreciated by professional baristas.

FR Permet au barman d'observer l'extraction du café qui sort du porte-filtre sans devoir se pencher. Un petit détail qui sera très apprécié par les barmans professionnels.

DE Gestattet es dem Barista, das Auslaufen des Kaffees aus dem Sieb zu beobachten, ohne sich bücken zu müssen. Eine kleine Aufmerksamkeit, die ein Profi-Barista sicher zu schätzen weiß.

ES Permite al barista observar la salida del café desde el portafiltro sin tenerse que inclinar. Un pequeño detalle que será muy apreciado por los baristas profesionales.

EN Lighting the inside of the milk jug, till now one of the darkest corners for the barista, allowing optimal sight of the foaming phase.

FR Point d'éclairage à l'intérieur du broc à lait, dans l'un des angles les plus obscurs pour le barman, lui permettant ainsi de voir parfaitement la phase de montage du lait.

DE Bringt Licht ins Innere des Milchkännchen, d.h. in einen der für den Barista dunkelsten Winkel, so dass er das Aufschäumen der Milch bestens sehen kann.

ES Hace luz dentro de la jarrita de la leche, o sea, en una de las esquinas más oscuras para el barista, permitiéndole visualizar de manera óptima la fase de montaje.

EN The work surface lighting system is also new, guaranteeing uniform light intensity over the entire surface.

FR Nouveauté aussi pour le système d'éclairage du plan de travail qui garantit une intensité de lumière uniforme sur toute la surface.

DE Eine weitere Neuerung ist das Beleuchtungssystem der Arbeitsfläche, welches eine gleichmäßige Ausleuchtung der gesamten Fläche gewährleistet.

ES También es nuevo el sistema de iluminación del plano de trabajo que garantiza uniforme intensidad de luz en toda la superficie.

EN The steam nozzles have the patented *cool touch* system, which in addition to greater security against annoying scalding, ensures easy cleaning; no more milk encrustation.

FR Les buses vapeur ont un système breveté *cool touch*, qui, outre à garantir une majeure sécurité d'emploi contre le risque de brûlures, assure un nettoyage simplifié; finies les incrustations de lait.

DE Die Dampfrohre sind mit dem patentierten System *cool touch* ausgestattet, das nicht nur unangenehmen Verbrennungen vorbeugt, sondern auch die Reinigung erleichtert. Schluss mit festgebackener Milch.

ES Las boquillas de vapor tienen el sistema patentado *cool touch*, que, además de garantizar mayor seguridad contra fastidiosas quemaduras, asegura una limpieza más fácil; stop a las incrustaciones de leche.

Razionalità e semplicità

Rationality and simplicity



Shot time



Brewing temperature



Group temperature



Boiler pressure



Additional pre-infusion



Energy saving



Smart functions

IT Tante utili funzione elettroniche disponibili con la nuova centralina che equipaggia le versioni *Digit* e T^3 : daily on-off programmabile, autodiagnosi, doppio conteggio erogazioni, programmazione allarmi, PID, funzione Energy Saving, gestione scaldatazze, gestione autosteam, ... sono solo alcune delle funzioni che la rendono semplice e intelligente.

EN Many useful features are available with the electronic control unit in the new *Digit* and T^3 versions: programmable daily on-off, self-diagnosis, double counting, programmable alarms, PID, Energy Saving function, cup warmer management, Autosteam management, ... are just some of the features that make it simple and smart.



LCD display

IT Alla nuova centralina è associato un display LCD che consente al barista di settare e/o monitorare i parametri di erogazione:

- Shot time
- Brewing temperature – T^3
- Group temperature – T^3
- Boiler pressure
- Additional pre-infusion
- Energy saving

EN The new unit has an LCD display that allows the barista to set and / or monitor output parameters:

- Shot time
- Brewing temperature – T^3
- Group temperature – T^3
- Boiler pressure
- Additional pre-infusion
- Energy saving

Rationalité
et simplicité

Klarheit und
Übersichtlichkeit

Racionalidad
y simplicidad



FR Aurelia II offre de nombreuses fonctions électroniques, disponibles avec la nouvelle centrale dont sont équipées les versions *Digit* et **T3**: daily on-off programmable, auto-diagnostic, double comptage des extractions, programmation des alarmes, PID, fonction Energy Saving, gestion chauffe-tasses, gestion Autosteam, sont seulement quelques-unes des fonctions qui la rendent simple et intelligente.

DE Die neue Steuerung der Ausführungen *Digit* und **T3** bietet zahlreiche, hilfreiche elektronische Funktionen: programmierbares daily on-off, Eigendiagnose, doppelter Zähler, Programmierung des Alarms, PID, Energiesparfunktion, Steuerung Tassenwärmer, Steuerung Autosteam, ... um nur einige der Funktionen zu nennen, dank der diese Maschine einfach und intelligent ist.

ES Muchas funciones útiles electrónicas disponibles con la nueva centralita que equipa las versiones *Digit* y **T3**: daily on-off programable, autodiagnóstico, doble cuenta dispensaciones, programación alarmas, PID, función Energy Saving, control calienta tazas, control autosteam ... son sólo algunas de las funciones que la hacen sencilla e inteligente.

FR La nouvelle centrale est associée à un afficheur LCD qui permet au barman de régler et/ou de surveiller les paramètres d'extraction:

- Shot time
- Brewing temperature – **T3**
- Group temperature – **T3**
- Boiler pressure
- Additional pre-infusion
- Energy saving

DE Zur neuen Steuerung gehört auch ein LCD-Display, das es dem Barista gestattet, die Ausgabe-Parameter einzustellen bzw. zu überwachen:

- Shot time
- Brewing temperature – **T3**
- Group temperature – **T3**
- Boiler pressure
- Additional pre-infusion
- Energy saving

ES A la nueva centralita se asocia una pantalla LCD que permite al barista ajustar y/o controlar los parámetros de dispensación:

- Shot time
- Brewing temperature – **T3**
- Group temperature – **T3**
- Boiler pressure
- Additional pre-infusion
- Energy saving

T3

La nuova dimensione della qualità

IT Aurelia Competizione incorpora l'innovativa tecnologia **T3** che è stata sviluppata dalla Nuova Simonelli facendo tesoro delle ricerche scientifiche effettuate presso prestigiosi centri universitari, dell'esperienza maturata nei campionati del World Barista Championship e soprattutto della collaborazione intercorsa con i baristi campioni del WBC. Aurelia II stabilisce nuovi standards di riferimento in termini di precisione, affidabilità e flessibilità delle prestazioni.



The new dimension of quality

EN Aurelia Competition incorporates innovative T³ technology, developed by Nuova Simonelli taking advantage of scientific research from prestigious universities, experience with the World Barista Championship and above all work with WBC championship baristas Aurelia II sets new standards of reference in terms of precision, reliability and performance flexibility.

La nouvelle dimension de la qualité

FR Aurelia Competizione incorpore la nouvelle technologie T³ qui a été développée par Nuova Simonelli grâce aux recherches scientifiques effectuées auprès de centres universitaires prestigieux, à l'expérience acquise lors des championnats du World Barista Championship et surtout grâce à la collaboration avec les barman vainqueurs du WBC. Aurelia II établit donc de nouveaux standards de référence en termes de précision, de fiabilité et de flexibilité des performances.

Die neue Dimension der Espresso-Qualität

DE Aurelia Competizione beinhaltet die innovative Technologie T³, die von Nuova Simonelli aufgrund wissenschaftlicher Studien bei angesehenen Universitäten, der bei den Meisterschaften der World Barista Championship gesammelten Erfahrung und insbesondere aufgrund der Zusammenarbeit mit den Meister-Baristas des WBC entwickelt wurde. Aurelia II setzt neue Standards im Hinblick auf Präzision, Zuverlässigkeit und Flexibilität der Leistungen.

La nueva dimensión de la calidad

ES Aurelia Competizione incorpora la innovadora tecnología T³ que ha desarrollado la Nuova Simonelli haciendo tesoro de las investigaciones científicas efectuadas en prestigiosos centros universitarios, con experiencia desarrollada en los campeonatos del World Barista Championship y sobretudo con la colaboración compartida con los baristas campeones del WBC. Aurelia II establece nuevos estándares de referencia en términos de precisión, fiabilidad y flexibilidad de los rendimientos.

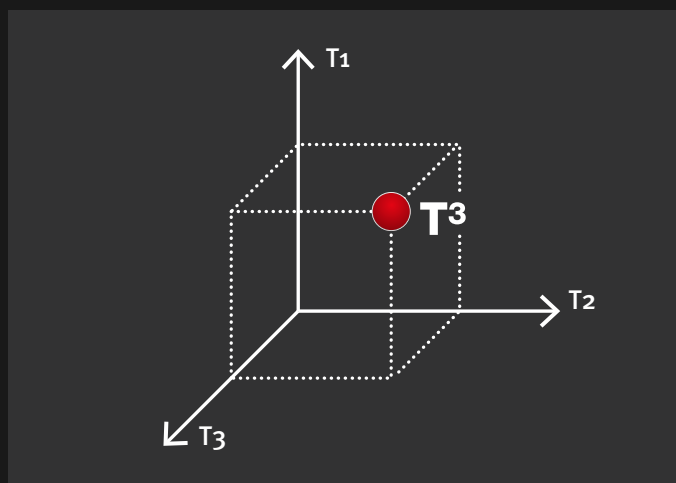
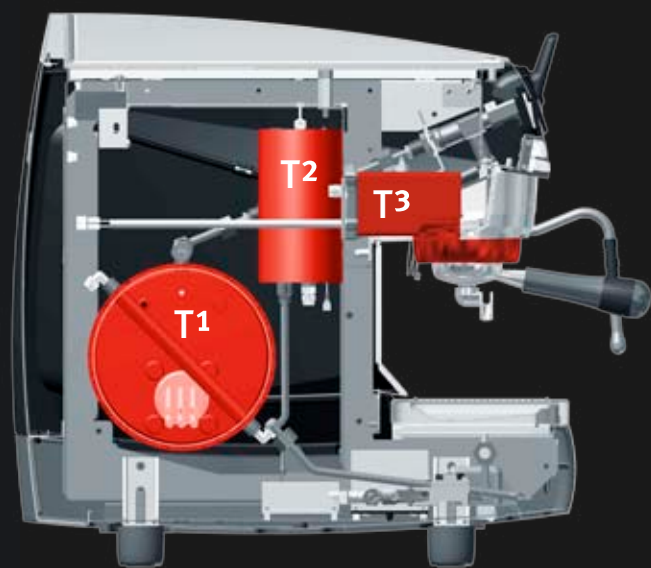

IT La tecnologia T³ garantisce performance ancora più evolute, perché effettua su ogni gruppo un controllo tridimensionale della temperatura. La lettura e la gestione diventano così particolarmente accurate. Associata ad una reattività in tempo reale della macchina, garantisce una straordinaria capacità di adattarsi perfettamente alle peculiarità di ogni miscela di caffè.

EN The T³ technology provides even more advanced performance, because on each group there is three-dimensional temperature control. So reading and operating become very accurate. Coupled with a real-time responsiveness of the machine, is the guarantee of an extraordinary ability to perfectly adapt to the characteristics of each coffee blend.

FR La technologie T³ garantit des performances encore plus évoluées car elle effectue un contrôle tridimensionnel de la température sur chaque groupe. La lecture et la gestion deviennent ainsi particulièrement précises. Associée à une réactivité en temps réel de la machine, elle garantit une capacité extraordinaire de s'adapter parfaitement aux caractéristiques de chaque mélange de café.

DE Die Technologie T³ gewährleistet noch fortschrittlichere Leistungen, da sie an jeder Brühgruppe eine dreidimensionale Kontrolle der Temperatur ausführt. Erfassung und Steuerung werden dadurch noch genauer. In Verbindung mit der ungemein hohen Reaktionsgeschwindigkeit der Maschine gewährleistet sie eine außerordentliche Fähigkeit, sich perfekt den Besonderheiten jeder Kaffeemischung anzupassen.

ES La tecnología T³ garantiza rendimientos todavía más avanzados, porque efectúa en cada grupo un control tridimensional de la temperatura. La lectura y la administración de esta manera son especialmente precisas. Asociada a una reactividad en tiempo real de la máquina, garantiza una extraordinaria capacidad para adaptarse perfectamente a las peculiaridades de cada mezcla de café.



Pressure adjustment

IT Con Aurelia II **T3** anche la regolazione della pressione pompa è agevolata. Il barista può così agire direttamente, senza dover aprire la macchina o chiamare il tecnico di fiducia, per adattare la pressione alle sue esigenze.

EN With Aurelia II **T3** the pump pressure can also be adjusted. The barista can do so directly, without having to unlock the machine or call a trusted technician, to adapt the pressure to his needs.



Thermal insulation

IT Prestazioni eccellenti e bassi consumi non sono obiettivi incompatibili per Aurelia II **T3**. Ogni parte del sistema idraulico è isolato termicamente con materiale tecnico per garantire massima costanza e minima dispersione energetica. Attraverso l'elettronica puoi spegnere uno o più gruppi nelle fasi di minor lavoro, abbattendo ulteriormente i consumi.

EN Excellent performance and low energy use are not mutually exclusive goals for Aurelia II **T3**. Each part of the hydraulic system is thermally insulated with technical material to ensure maximum consistency and minimum energy loss. Through the electronics one or more groups can be turned off in low workload phases, further reducing energy use.



Steam stop valve

IT Fare manutenzione del sistema vapore senza dover arrestare il funzionamento della macchina è il sogno di tanti baristi e tecnici. Con Aurelia II **T3** ora si può. Ogni lancia è equipaggiata di una valvola che consente di interrompere il passaggio del vapore. Si può così intervenire sulla lancia mentre si servono cappuccini ai clienti.

EN Maintaining the steam system without stopping the machine functioning is the dream of many baristas and technicians. With Aurelia II **T3** you now can. Each nozzle is equipped with a valve which can block steam. So you can maintain the nozzle while still serving cappuccinos to customers.



Teflon filter holder

IT Aurelia II **T3** è equipaggiata dei particolari portafiltri con rivestimento in teflon che offre maggiore pulizia e quindi preserva l'aroma del caffè in tazza. Su richiesta si può avere anche il sistema *easy clean* che garantisce lo smontaggio agevolato dei becchi erogazione.

EN Aurelia II **T3** is equipped with the special teflon coated holder that offers greater cleanliness and thus preserves the aroma of coffee in the cup. The *easy clean* system is also available on demand. It ensures simple removal of the delivery nozzles.

Technique et professionnalisme

FR Avec Aurelia II [T3], même le réglage de la pression pompe est simplifié. Le barman peut ainsi agir directement, sans devoir ouvrir la machine ou appeler son technicien habituel, pour adapter la pression à ses exigences.

FR Les performances excellentes et l'économie d'énergie ne sont pas des objectifs incompatibles avec Aurelia II [T3]. Chaque partie du système hydraulique est isolé thermiquement avec un matériel technique afin de garantir une constance maximum et une moindre dispersion d'énergie. A travers l'électronique, vous pouvez éteindre un ou plusieurs groupes pendant les phases de travail plus légère, en réduisant ainsi les consommations d'énergie.

FR Effectuer l'entretien du système vapeur sans devoir interrompre le fonctionnement de la machine est le rêve de tous les barmans et de tous les techniciens. Avec Aurelia II [T3], cela est maintenant possible. Chaque buse vapeur est équipée d'une soupape qui permet d'interrompre le passage du vapeur. On peut ainsi intervenir sur la buse vapeur pendant qu'on sert des cappuccinos aux clients.

FR Aurelia II [T3] est équipée de porte-filtres spéciaux revêtus de téflon qui offre une majeure hygiène et qui préserve donc l'arome du café dans la tasse. Il est possible également, sur demande, de munir la machine du système *easy clean* qui garantit le démontage aisé des becs d'extraction.

Technologie und Professionalität

DE Bei Aurelia II [T3] ist auch der Pumpendruck leichter zu regeln. Der Barista kann den Druck direkt seinen Bedürfnissen anpassen, ohne die Maschine öffnen oder seinen Fachtechniker rufen zu müssen.

DE Exzellente Leistungen und niedriger Verbrauch sind Ziele, die bei Aurelia II [T3] durchaus nicht im Widerspruch stehen. Jeder Teil des Hydrauliksystems ist durch technisches Material thermisch isoliert, um höchste Gleichmäßigkeit und minimale Energieverschwendung zu gewährleisten. Dank der Elektronik können in Zeiträumen mit weniger Kundenzulauf eine oder mehrere Brühgruppen abgeschaltet werden, so dass der Energieverbrauch noch zusätzlich gesenkt wird.

DE Die Wartung des Dampfsystems ohne Unterbrechung des Maschinenbetriebs ist der Traum vieler Baristas und Techniker. Mit Aurelia II [T3] ist es möglich. Jedes Dampfrohr ist mit einem Ventil ausgestattet, das die Unterbrechung des Dampfes ermöglicht. Das Dampfrohr kann also nach Belieben benutzt werden, wenn den Kunden Cappuccino serviert werden soll.

DE Aurelia II [T3] ist mit speziellen, teflonbeschichteten Siebhaltern ausgestattet, die bessere Sauberkeit bieten und somit das Aroma des Kaffees wahren. Auf Wunsch ist auch das System *easy clean* lieferbar, das ein besonders bequemes Abmontieren der Ausgusschnäbel ermöglicht.

Tecnica y profesionalismo

ES Con Aurelia II [T3] también la regulación de la presión de la bomba está facilitada. El barista puede de esta manera actuar directamente, sin tener que abrir la máquina o llamar al técnico de confianza, para adaptar la presión a sus exigencias.

ES Rendimientos excelentes y bajos consumos no son objetivos incompatibles para Aurelia II [T3]. Cada parte del sistema hidráulico está aislado térmicamente con material técnico para garantizar la máxima constancia y la mínima dispersión energética. A través de la electrónica se pueden apagar uno o varios grupos en las fases de menor trabajo, abatiendo ulteriormente los consumos.

ES Hace el mantenimiento del sistema vapor sin tener que detener el funcionamiento de la máquina es el sueño de tantos baristas y técnicos. Con Aurelia II [T3] ahora se puede. Cada boquilla está equipada con una válvula que permite interrumpir el pasaje del vapor. Se puede de esta manera intervenir en la boquilla mientras se sirven capuchinos a los clientes.

ES Aurelia II [T3] está equipada con los especiales portafiltros con revestimiento en teflón que ofrece mayor limpieza y por lo tanto preserva el aroma del café en la taza. Bajo petición se puede tener también el sistema *easy clean* que garantiza el desmontaje facilitado de las boquillas de dispensación.

Aurelia II

T3

IT Dedicata a:

- Baristi campioni
- Baristi super-professionisti
- Locali che propongono caffè diversi
- Locali focalizzati sulla qualità del caffè

EN Dedicated to:

- Champion baristas
- Super professional baristas
- Shops that offer a variety coffees
- Shops focused on coffee quality

FR Dédié à:

- Barmans vainqueurs
- Barmans super-professionnels
- Etablissements qui offrent un vaste choix de café
- Etablissements focalisés sur la qualité du café

DE Speziell für:

- Meister-Baristas
- Superprofessionelle Baristas
- Lokale, die eine große Auswahl an Kaffee bieten
- Lokale, die sich auf die Qualität des Kaffees konzentrieren

ES Dedicada a:

- Baristas campeones
- Baristas súper profesionales
- Locales que ofrecen una variedad de café
- Locales focalizados sobre la calidad del café

Standard



Reverse mirror



Milk light



Led light



Cool touch



PID



SIS



Automatic cleaning



Smart functions



LCD display



Pressure adjustment



Thermal insulation



Steam stop valve



Teflon filter holder

Optional



Leather filter holder



Cup warmer

Aurelia II T3
2 groups





Aurelia II T3 – 3 groups



Aurelia II

Digit

IT Dedicata a:

- Professionisti esigenti
- Catene coffee shops
- Locali con elevate performance qualitative
- Locali alto vendenti

EN Dedicated to:

- Demanding professionals
- Coffee shop chains
- Shops with high quality performance
- High turnover shops

FR Dédié à:

- Professionnels exigeants
- Chaînes Coffee shops
- Etablissements avec hautes performances qualitatives
- Etablissements à grands volumes de vente

DE Speziell für:

- Anspruchsvolle Profis
- Coffeeshop-Ketten
- Lokale mit hohen Qualitätsansprüchen
- Lokale mit hohen Verkaufszahlen

ES Dedicada a:

- Profesionales exigentes
- Cadenas Coffee shops
- Locales con elevados rendimientos cualitativos
- Locales con altas ventas

Standard



Reverse mirror



PID



SIS



Automatic cleaning



Smart functions



LCD display

Optional



Autosteam



Cool touch



Milk light



Led light



Raised groups



Teflon filter holder



Leather filter holder



Cup warmer

Aurelia II Digit
2 groups + Autosteam





Aurelia II Digit



Aurelia II

S Semiautomatic

V Volumetric

IT Dedicata a:

- Professionisti esigenti ma attenti al costo
- Locali alto-medio vendenti
- Locali con medio-alto esigenze qualitative

EN Dedicated to:

- Demanding Professionals in terms of quality and cost
- Medium-high turnover shops
- Medium-high quality performance shops

FR Dédié à:

- Professionnels exigeants en termes de qualité et de coût
- Etablissements à moyens/hauts volumes de vente
- Etablissements à moyennes/hautes performances qualitatives de vente

DE Speziell für:

- Anspruchsvolle Profis im Hinblick auf Qualität und Kosten
- Lokale mit mittleren bis hohen Verkaufszahlen
- Lokale mit mittlerer bis hoher Leistungsqualität

ES Dedicada a:

- Profesionales exigentes en términos de calidad y de coste
- Locales de ventas medio-altas
- Locales con rendimientos cualitativos medio-altos

Standard



Reverse mirror



SIS



Automatic cleaning (Volumetric)

Optional



Autosteam (Volumetric)



Cool touch



Milk light



Led light



Raised groups



Teflon filter holder



Leather filter holder



Cup warmer

Aurelia II S – 3 groups





Aurelia II V – 2 groups (raised)



AURELIA III

La migliore Aurelia di sempre
The best Aurelia of all times



Versione / Version		2 gr			T ³ S	T ³ V
Modello / Model		S	V	Digit		
Carrozzeria Body	Materiale Material	Acciaio inox con inserti in ABS / Stainless Steel with ABS insert				
	Colori standard Colours	■ Nero / Black	□ Bianco perla / Pearl white	■ Rosso / Red		
	Kit Led completo Full LED light kit	○	○	○	●	●
Caldaia Boiler	Capacità Boiler capacity	14 lt	14 lt	14 lt	14 lt	14 lt
	Materiale Material	Rame /Copper	Rame /Copper	Rame /Copper	Rame /Copper	Rame /Copper
	Valvola sicurezza Security Valve	●	●	●	●	●
	Valvola antirisucchio No-vacuum valve	●	●	●	●	●
	Pressostato Pressostat	Manual	Manual	Digital	Digital	Digital
Idraulica Hydraulics	Autolivello elettronico Automatic water flow	●	●	●	●	●
	Pompa volumetrica Volumetric pump	●	●	●	●	●
	Regol. esterna pompa External pump adjustm.	●	●	●	●	●
	Dosatura volumetrica Volumetric dosage	●	●	●	●	●
	Manometro (bar pompa) Gauge (bar pump)	●	●	●	●	●
	Manometro caldaia Gauge (boiler)	●	●	Electronic	Electronic	Electronic
	Indicatore livello acqua Water level indicator	●	●	●	●	●
Gruppo Group	Reg. temp. gruppo Group temp. adjustm.	Termosifonic	Termosifonic	Termosifonic	Electronic	Electronic
	Infusione SIS Soft infusion system (SIS)	●	●	●	●	●
	N. stabilizzatori gruppo N. group stabilisers				2	2
	Capacità stabilizz. gruppo Group stabilaiser capacity				0,7	0,7
	Gruppi altezza maggiorata Raised groups	○	○	○		
	Portafiltro teflonato Teflon filter holder	○	○	○	●	●
	Portafiltro pelle + teflon Filter holder leather + teflon	○	○	○	○	○
Vapore Steam	N. lance vapore N. steam wands	2	2	2	2	2
	Acciaio inox Stainless steel	●	●	●	●	●
	Lancia cool touch Cool touch wand	○	○	●	●	●
	Rubinetto interruttore circuito Steam stop valve	○	○	●	●	●
	Autosteam Autosteam	○	○	○		
Acqua calda Hot water	N. lance N. lance	1	1	1	1	1
	Economizzatore acqua calda Hot water economiser	●	●	●	●	●
	Dosatura acqua calda Hot water dosage	●	●	●	●	●
Scaldatazze Cup warmer	Elettrico On/Off On/Off electric	○	○			
	Temp. programmabile Programmable temp.			○	○	○
Elettronica Electronic	Display LCD Display LCD			●	●	●
	On/Off On/Off			●	●	●
	Conteggio totale/parziale Partial/total Counter			●	●	●
	Autodiagnosi Check control			●	●	●
	Lavaggio autom. Autom. cleaning program		●	●	●	●
	Tempo erogazione Shot time			●	●	●
	Temp./press. caldaia Temp./press. boiler			●	●	●
	Temp. acqua caffè Brewing water temp.			●	●	●
	Temp. latte (Autosteam) Milk temp. (Autosteam)			●		
	Program. temp. acqua caffè Coffee water temp. program				●	●
	Program. temp. gruppo Group temp. program				●	●
	Program. addolc Water softer program			●	●	●
Program. manut. Maintenance program			●	●	●	
Program. temp. caldaia Boiler temp. program			●	●	●	
Dimensioni Dimension	A - Larghezza (mm) A - Width (inch)	815 (32 1/16)	815 (32 1/16)	815 (32 1/16)	815 (32 1/16)	815 (32 1/16)
	H - Altezza (mm) H - Height (inch)	565 (22 3/16)	565 (22 3/16)	565 (22 3/16)	565 (22 3/16)	565 (22 3/16)
	C - Profondità (mm) C - Depth (inch)	565 (22 3/16)	565 (22 3/16)	565 (22 3/16)	565 (22 3/16)	565 (22 3/16)
	B - Larghezza (mm) B - Width (inch)	720 (28 5/16)	720 (28 5/16)	720 (28 5/16)	720 (28 5/16)	720 (28 5/16)
	D - Profondità (mm) D - Depth (inch)	370 (14 9/16)	370 (14 9/16)	370 (14 9/16)	370 (14 9/16)	370 (14 9/16)
Peso Weight	Peso netto (kg) Net weight (lb)	74 (164)	74 (164)	74 (164)	76 (168)	76 (168)
	Peso lordo (kg) Gross weight (lb)	80 (176)	80 (176)	80 (176)	82 (181)	82 (181)
Potenza Power	Voltaggio Voltage	230 - 380V	230 - 380V	230 - 380V	230 - 380V	230 - 380V
	Potenza massima Maximum power	4500W	4500W	4500W	7300W	7300W
Suggerimenti Installazione / Hint installation						
Piano Macchina Top dimension	Larghezza min. Minimum width	1100 (43 1/4)	1100 (43 1/4)	1100 (43 1/4)	1100 (43 1/4)	1100 (43 1/4)
	Profondità sugg. (mm) Depth (inch)	600 (23 9/16)	600 (23 9/16)	600 (3 9/16)	600 (23 9/16)	600 (23 9/16)
	Altezza sugg. (mm) Height (inch)	1040 (40 15/16)	1040 (40 15/16)	1040 (40 15/16)	1040 (40 15/16)	1040 (40 15/16)
	Diametro foro (mm) Hole diameter (inch)	60 (2 5/16)	60 (2 5/16)	60 (2 5/16)	60 (2 5/16)	60 (2 5/16)
Ingr. acqua Water inflow	Dist. max rubinetto (mm) Max dist. from water tap (inch)	1000 (39 5/16)	1000 (39 5/16)	1000 (39 5/16)	1000 (39 5/16)	1000 (39 5/16)
	Attacco Pipe connection	3/8	3/8	3/8	3/8	3/8
Impianto elettr. Wiring	Dist. max prese (mm) Max dist. (inch)	1000 (39 5/16)	1000 (39 5/16)	1000 (39 5/16)	1000 (39 5/16)	1000 (39 5/16)
	Se impianto 380V If 380V	Trif. con neutro	Trif. con neutro	Trif. con neutro	Trif. con neutro	Trif. con neutro
	Amper macch. Ampere	20	20	20	30	30

● standard ○ optional

www.nuovasimonelli.it

memphiscom.it

cod. ????????



Nuova Simonelli S.p.A
Via M. D'antegiano, 6
62020 Belforte del Chienti
Macerata Italy
Tel. +39.0733.9501
Fax +39.0733.950242
Videoconf. +39.0733.950201
www.nuovasimonelli.it
n.simonelli@nuovasimonelli.it

Nuova Distribution Usa
6940 Salashan PKWY, BLDG, A
Ferndale, WA 98248
Tel. +1.360.3662226
Fax +1.360.3664015
Videoconf. +1.360.3188595
www.nuovadistribution.com
info@nuovadistribution.com

